

FOREWORD

The Building and Construction Authority's (BCA) Construction Quality Assessment System (CONQUAS) has been widely adopted as the de facto national yardstick for measuring the quality of building projects. To meet the rising expectations of homeowners, the Quality Mark (QM) Scheme was launched in 2002 to promote a higher consistency in workmanship standards for residential developments. Besides setting standards and measuring the level of workmanship through CONQUAS and QM, BCA has developed a series of publications of Good Industry Practices Guide for different trades.

This "Good Industry Practices – Drywall Internal Partition" is part of the CONQUAS Enhancement Series on Good Industry Practices. A noticeable increase in the use of drywall has been observed in the construction industry over the years. Drywall construction has emerged as one of the leading options towards achieving quality finishing with higher productivity without compromising its primary functionality as an internal wall. The use of drywall is also encouraged and recognised under CONQUAS 8th edition. This guide shares with the industry some of the good practices adopted by practitioners and contractors who consistently deliver high quality work in drywall construction. It provides simple and practical illustrations to users on how good quality work can be achieved with high productivity. Common defects associated with drywall internal partition and their corresponding remedies are highlighted. With the tight manpower constraints faced by the industry, drywall construction is a highly practical option.

This guide is not meant to be a definitive textbook on how drywall must be designed and installed, nor is it the final word on quality, as there will always be new materials and methods with changing technology. To obtain more comprehensive information and guidance, readers should seek advice from professional designers and material suppliers. We gratefully acknowledge the contributions of the practitioners to this guide and trust that the industry will find this publication useful in its pursuit of quality excellence. We welcome any contributions from readers that may improve future editions of this guide.



LAM SIEW WAH

*Deputy Chief Executive Officer
Industry Development
Building and Construction Authority*

ACKNOWLEDGEMENT

This “Good Industry Practices Guide – Drywall Internal Partition” was developed with inputs from Architects, Developers, Builders, Specialist Contractors and members from various industry associations and organisations.

A Technical Committee was formed to review the contents and good practices identified. We wish to thank the members of the Technical Committee for their valuable contributions.

Technical Committee:

Chairman	Mr Ding Hock Hui	BCA
Deputy Chairman	Mr Tan Boon Kee	BCA
Secretary	Mr Gary Chua Chei Seong	BCA
	Ms Jacelyn Yeo Hui Ping	BCA
Members	Mr Ng Kam Leong	BCA
	Mr Ramamoorthy Rajendran	BCA
	Ms Jayanthi Peariahsamy	BCA
	Mr Donald Ng	HDB
	Mr Zachary Chua	SCAL
	Mr Chng Chee Beow	REDAS
	Mr Richard Lai	Singapore Institute of Architects
	Mr Gary Cher	City Developments Ltd
	Mr Thierry Brezac	Dragages Singapore Pte Ltd
	Mr Colin Tan	Tiong Seng Contractors Pte Ltd
	Mr Jerry Lam	Woh Hup Pte Ltd
	Mr Billy Cho and Mr Daniel Lee	Pacific Interiors Supply (PIS Pte Ltd)
	Mr Teo Wee Hwee	Boral Plasterboard (Malaysia) Sdn Bhd

We would also like to thank the following organisations and individuals for their valuable feedback in the review of this guide:

Singapore Civil Defence Force	Dragages Singapore Pte Ltd
Institution of Engineers Singapore	Lian Beng Construction (1988) Pte Ltd
Singapore Institute of Building Limited	Mr Russell Cole
CapitaLand Limited	Er. Rose Nguan
City Developments Ltd	Ms Tan Lay Twan
Ong & Ong Corporation	Mr Desmond Hill



TAN TIAN CHONG

Group Director

Technology Development Division

CONTENTS

1. INTRODUCTION	1
2. DESIGN	2
2.1 Drywall Systems	3
3. MATERIAL SELECTION	6
3.1 Framing System	6
3.2 Board Usage	8
3.3 Infill and Insulation Materials	10
3.4 Type of Joint Materials	11
3.5 Accessories	13
3.6 Tools Selection	15
4. DELIVERY, HANDLING AND STORAGE	17
5. PREPARATORY WORKS	19
5.1 Approved Shop Drawing, Method Statement, Material and Sample	19
5.2 Contact Surface Preparation	21
5.3 Setting Out Preparation	23
6. INSTALLATION	25
6.1 Framing Works	25
6.2 Opening	28
6.3 Additional Supports for M&E Services and Other Fixtures	30
6.4 Board Installation	32
6.5 Infill and Insulation Installation	36
6.6 Joint Treatment	37
6.7 Fixing Items to Drywall	42
7. PROTECTION	43
8. WET AREAS APPLICATION	45
8.1 Board System	45
8.2 Recommended Good Practices	46
9. RECOMMENDED DETAILING	48
10. COMMON DEFECTS AND REMEDIES	52
APPENDIX	58
Appendix A. Wall Comparison By Function Requirements	58
Appendix B. Sample of Fixing Items	59
Appendix C. Sample of Inspection and Test Plan	61
Appendix D. Request for Inspection Form	67
REFERENCES	68

I. INTRODUCTION

Internal wall is an essential element for all buildings. There are different types of materials used for internal wall construction. Given the high and increasing property prices, home owners' expectations of quality homes and buildings have also risen in tandem. The tight manpower situation has also led to finding solutions that are productive, cost effective and environmentally friendly.

Drywall construction has emerged as the leading option towards achieving quality finishing with higher productivity without compromising its primary functionality as an internal wall. Drywalls are lightweight (approximately 10-15% the weight of conventional brick walls), which can result in reduced structural loads on foundations thus reducing structural, piling and foundation costs. Mechanical and electrical services can easily be embedded within drywalls. There is no need to hack walls to embed services as when conventional brick or block walls are used. The use of drywalls facilitates dry construction, eliminating messy plastering works as its smooth and even surfaces are ready to receive paint finishes directly. Drywall systems are easily installed, can be redesigned and quickly relocated according to one's needs with no noisy and untidy hacking of concrete or bricks. Drywall construction is cleaner, quieter and environmentally friendly.

Apart from high quality finish and productivity, drywall systems contribute to higher buildable and constructability scores where minimum standards are now mandated. Designers and builders should consider this system for their projects. In the CONQUAS 8th edition, the use of drywalls and its impact on quality are also recognised and encouraged. Award points are given where drywalls are used leading to improved CONQUAS score for the project.

While there are some common misperceptions about drywalls, this guide serves to dispel them. With improvements in manufacturing technology and design, drywalls are now able to meet, if not exceed, the standards expected of conventional brick or block wall construction in areas like acoustic performance, thermal insulation and resistance to fire and damp conditions. This has led to many leading and progressive developers using drywalls in their higher end residential projects.

This guide therefore provides simple and practical tips on how good quality drywall can be achieved on site. It highlights the salient quality issues involved in the design, material selection, and installation of drywalls. Following the processes in this guide will lead to higher quality standards, better buildable and constructability scores and improved productivity.

2. DESIGN

There is a wide range of wall partitions available in the market. Design of wall partition should take into consideration the functional performance, structural performance and appearance. In this guide, the focus will be on drywall internal partition system. Where the drywall is designed to meet fire safety standards e.g. as fire compartmentation wall, the regulatory requirements should be followed.

Table 2.1 Brick Wall and Drywall Comparison by Functional Requirements (Based on floor to floor height of 3m)

Requirements	Conventional Brick (100mm thick)	Drywall Partition (~100mm thick)
Weight	900 kg/ m	~113 kg/ m
Productivity	4 – 7m ² /man-day	20– 25m ² /man-day
Non-Combustibility BS 476 : Pt 4	Deemed to satisfy	Pass
Fire Rating BS 476 : Pt 20 & Pt 22	120 mins	120 mins
Sound Insulation	STC35 – STC40	~ STC50
Usage in Wet Areas	Yes	Yes
On-Site Installation of Concealed Wiring, Ducting & Pipework	By surface hacking 	By fitting services before closing up 
Surface Appearance	Smooth with plastering (Only with skilled plasterer)	Smooth after joint compound
Applied Finishes: Tiling	Yes	Yes
Joint Treatment	Mesh reinforcement between brick and adjoining concrete column/wall	Joint tape is used to seal joint followed by application of joint compound
Fastener Types	<ul style="list-style-type: none"> • Plastic Plugs • Chemical Anchors • Impact Anchors 	<ul style="list-style-type: none"> • Anti-corrosion Screws • Cavity Anchors
Flexibility of Relocation	Slow, Noisy, Dusty and Untidy	Quick and easy

*For more comparison, please refer to Appendix A

2.1 Drywall Systems



The following are the usual design considerations and features in drywall systems:-

- architectural;
- impact;
- fire resistance;
- acoustics;
- wet area usage; and
- high wall.



Figure 2.1 Drywall Design Considerations & Features

Design Consideration	Features
<p>1. Architectural</p> 	<ul style="list-style-type: none"> • Design flexibility • Flatter and smoother surface • Better finishes
<p>2. Impact</p> 	<ul style="list-style-type: none"> • Protection in high activity areas • Inter-tenancy wall security
<p>3. Fire Resistance</p> 	<ul style="list-style-type: none"> • Up to 4 hours fire rating • Non-combustible board
<p>4. Acoustics</p> 	<ul style="list-style-type: none"> • Noise control from both interior and exterior • Ability to develop quiet zones

Design Consideration	Features
<p>5. Wet Area Usage</p> 	<ul style="list-style-type: none">• Protection against steam & moisture• Better mould resistance• Better finishes
<p>6. High Wall</p> 	<ul style="list-style-type: none">• Structural stability*• Higher productivity• Better finishes <p>* To PE's design</p>

3. MATERIAL SELECTION

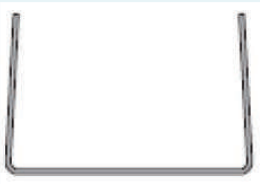


Different drywall systems have varying performance properties. This requires careful selection of materials to meet the performance requirements of the internal wall. The main material components for a drywall system include:-

- Framing system
- Plasterboard
- Infill and Insulation Material
- Joint Materials
- Accessories
- Tools

3.1 Framing System

The framing system comprises pre-measured locking runners/tracks with starter studs and bracing. The system will also take into consideration the provision of openings and additional support for other features according to the design.

Figure 3.1a Framing System

Components	Description
<p>Runner/Track</p> 	<p>The runners/tracks shall be galvanised steel U-section. They should be tight fit, solid web, and no less than thickness of studs.</p> <p>All steel sections are rolled from G250 tensile steel and galvanised to Z180 specification and having minimum section properties shown on approved shop drawings.</p>
<p>Stud</p> 	<p>The studs shall be galvanized steel C-studs. They are to be installed onto the runner/track vertically.</p> <p>All steel sections are rolled from G250 tensile steel and galvanised to Z180 specification and having minimum section properties shown on approved shop drawings.</p>
<p>Bracing</p> 	<p>Provide all braced framing of load bearing steel stud framing at regular interval in accordance to approved shop drawings and method statement. They are essential at locations such as door opening, M&E services and other fixtures to withstand the imposed load.</p>

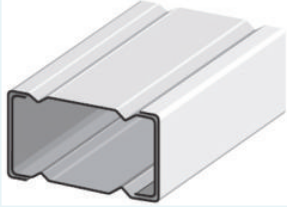

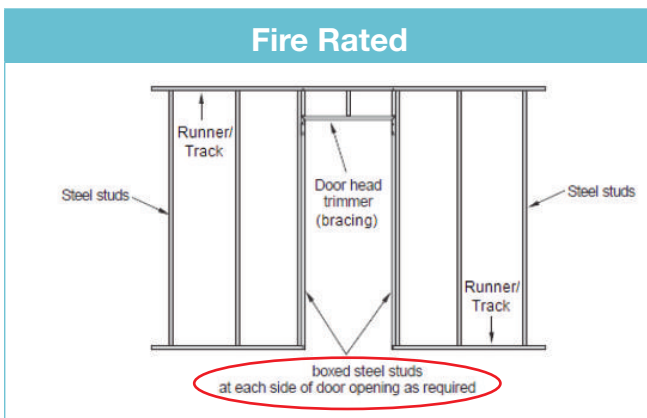
Components	Description
<p>Opening</p> 	<p>Studs should be boxed and mechanically fastened to the runner/track sections around all window and door openings, as a minimum.</p>
<p>Additional Support for M&E Services and Other Fixtures</p> 	<p>The interval of additional support to follow approved shop drawings and method statement e.g. for fan coil unit (FCU), bedroom wardrobe, kitchen cabinet, etc.</p>



Figure 3.1b Fire-rated Door Framing Layout



3.2 Board Usage

Drywall plasterboard selection is dependent on its usage (Table 2.1). It is critical to use the right product at the right location. The common types of boards used locally are gypsum based and calcium silicate mineral boards. There are other types of boards available in the industry such as cement board, metamorphic mineral board, etc. These boards have to fulfil one or more of the 4 main types of wall functions as indicated in Figure 3.2a according to the design intent. Figure 3.2b illustrates the different types of plasterboard edge profile.

Figure 3.2a Types of Boards

Types of Boards	Description
<p>Standard</p>  <p>A photograph of a standard green plasterboard with a white label at the bottom that reads "Standard".</p>	<ul style="list-style-type: none"> • Single layer board. • Impact resistance and durability. • Multi-purpose wall lining.
<p>Abuse Resistance</p>  <p>A photograph of an abuse-resistant plasterboard with a tan surface and a white label at the bottom that reads "ABUSE RESISTANT".</p>	<ul style="list-style-type: none"> • Single layer board. • Outperforms standard board in terms of abrasion, indentation and penetration. • Pull-Down Test.
<p>High Performance Sound Insulation</p>  <p>A photograph of a high-performance sound insulation plasterboard with a light green surface and a white label at the bottom that reads "Sound Insulation".</p>	<ul style="list-style-type: none"> • Single or multi-layer board (Typically one to four boards). • Sound Transmission Class (STC) value of drywall ranges from 40 to 60. • Acoustical Theory of 'Mass-Spring-Mass'. • For high performance sound insulation design, advice of an acoustic expert is recommended.




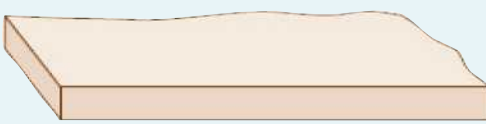
Types of Boards	Description
<p>High Fire Resistance</p> 	<ul style="list-style-type: none"> • Single or multi-layer board (Typically one to four boards). • Recommended minimum double boxed stud or double board. • Made from vermiculite, fibreglass and other additives that offset shrinkage and increase durability. • Fire rating above 1 hour and up to 4 hours.
<p>Wet Area (Water Resistance)</p> 	<ul style="list-style-type: none"> • Single water resistance board with additional waterproofing layer. • Long Term Moisture Susceptibility Test to Shower Unit. • Mould Resistance Test to ASTM standard. • Independent Tile Adhesion Pull-out Tension Test. • Acceptance of water-proofing treatment



Figure 3.2b Types of Board Edge Profiles

Types of Boards Edges	Usage
<p>Recessed Edge</p> 	<p>Designed for flush jointing with jointing compounds and accessories to provide a continuous smooth surface for walls and ceilings.</p>
<p>Square Edge</p> 	<p>Designed for use with aluminium, PVC, timber or other decorative moulding. It may be butt jointed using concealed fixing clips when laminated.</p>

3.3 Infill and Insulation Materials

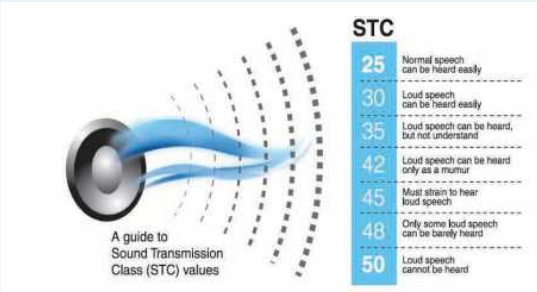

It is essential to ensure that all infill and insulation materials used carry a class ‘O’ non-combustibility certification. All materials have to be termite resistant. Figure 3.3a shows the common infill and insulation materials.

Figure 3.3a Infill and Insulation Material Types

Types	Characteristic
<p>Fibreglass</p> 	<ul style="list-style-type: none"> • Made from molten glass. • Insulation value is typically higher in slab or blanket as compared to loose fill. • More cost economic.
<p>Rockwool</p> 	<ul style="list-style-type: none"> • Consist of materials like basalt and limestone. • Higher insulation value (R-value) as compared to fibreglass. • Higher density than fibreglass which helps to improve fire resistance.

Infill and insulation for acoustic or thermal functions may be placed into the partition cavity.

Figure 3.3b Infill and Insulation Functions

Infill and Insulation Functions	Characteristic																
<p>1. Acoustic insulation</p>  <p>A guide to Sound Transmission Class (STC) values</p> <table border="1" data-bbox="555 1473 743 1742"> <thead> <tr> <th>STC</th> <th>Description</th> </tr> </thead> <tbody> <tr> <td>25</td> <td>Normal speech can be heard easily</td> </tr> <tr> <td>30</td> <td>Loud speech can be heard easily</td> </tr> <tr> <td>35</td> <td>Loud speech can be heard, but not understand</td> </tr> <tr> <td>42</td> <td>Loud speech can be heard only as a murmur</td> </tr> <tr> <td>45</td> <td>Must strain to hear loud speech</td> </tr> <tr> <td>48</td> <td>Only some loud speech can be barely heard</td> </tr> <tr> <td>50</td> <td>Loud speech cannot be heard</td> </tr> </tbody> </table>	STC	Description	25	Normal speech can be heard easily	30	Loud speech can be heard easily	35	Loud speech can be heard, but not understand	42	Loud speech can be heard only as a murmur	45	Must strain to hear loud speech	48	Only some loud speech can be barely heard	50	Loud speech cannot be heard	<p>Available rating range from STC25 to STC60, as achieved in acoustic tests. Comparable field performance depends on building design and careful attention to detailing and workmanship. It is important that the fill perimeter of the partition be sealed with an approved flexible acoustic sealant, as also all penetrations.</p>
STC	Description																
25	Normal speech can be heard easily																
30	Loud speech can be heard easily																
35	Loud speech can be heard, but not understand																
42	Loud speech can be heard only as a murmur																
45	Must strain to hear loud speech																
48	Only some loud speech can be barely heard																
50	Loud speech cannot be heard																
<p>2. Thermal insulation</p> 	<p>Thermal Resistance (R) values for the following board thickness under normal ambient temperatures are:</p> <p>10mm = 0.060m²K/W 13mm = 0.079m²K/W 16mm = 0.098m²K/W</p>																

3.4 Type of Joint Materials

Hairline cracks may appear over time particularly so after air-conditioning is in use at drywall joints. Such cracks can be mitigated with proper installation and joint treatment. It is recommended to provide joint materials (Figure 3.4a) to seal joint followed by the application of joint compound (Figure 3.4b). This will control the movement between the boards and prevents cracks from forming.

Figure 3.4a Types of Joint Materials


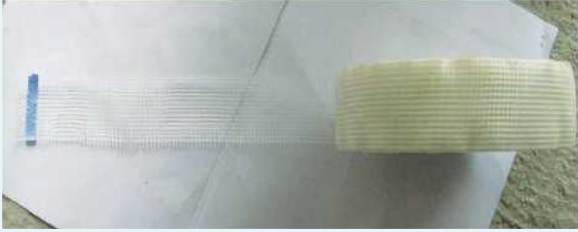



Types	Characteristic
<p>1. Perforated paper tape</p> 	<ul style="list-style-type: none"> • Embedded onto a bedding compound. • Control shrinkage cracking at the wall board joints • Applicable for dry areas
<p>2. Alkali-resistant fibreglass mesh tape</p> 	<ul style="list-style-type: none"> • Used on its own. • Self-adhesive backing allowing faster application in the absence of bedding compound • Ideal when water resistance is a requirement • Applicable for wet areas • Control shrinkage cracking at joints
<p>3. Glass fibre tissue</p> 	<ul style="list-style-type: none"> • Serves as a reinforcing bridge for paint film, covering hairline cracks that occur in the plaster substrate • Mitigates re-appearance of fine plaster cracks

Figure 3.4b Types of Joint Compounds

Types	Characteristic
1. Bedding compound	<ul style="list-style-type: none"> • Powder form. • Used with joint tape. • For superior bonding strength and crack resistance.
2. Topping compound	<ul style="list-style-type: none"> • Powder form. • Has good sandability, lower shrinkage and smooth finishing.
3. All-purpose compound	<ul style="list-style-type: none"> • Premixed form. • For taping, covering and finishing coats on wall board joints. • For concealing fastener holes and corner beads.

Table 3.4c Forms of Joint Compounds


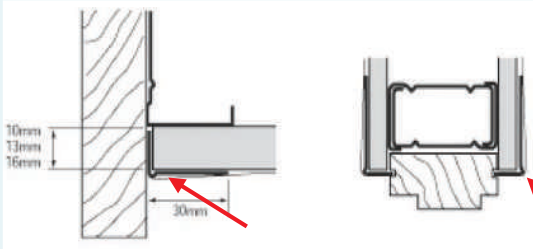

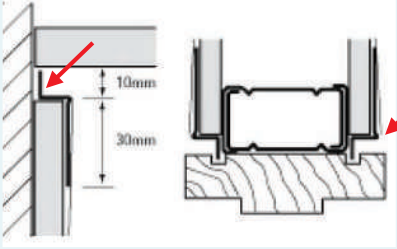
Forms	Usage
<p>1. Powder form</p> 	<ul style="list-style-type: none"> • Mixed with water in the ratio of 2 portions of powder to one portion of water. • Do not mix more than necessary to be used within the working time of about 30minutes as leftover compound cannot be reused.
<p>2. Premixed form</p> 	<ul style="list-style-type: none"> • Ready mixed compound. • Excellent performance and storage life compared to powders. • Less wastage as storage is possible for months in their containers even after opening.

3.5 Accessories

In general, the various types of accessories simplify and enhance the finishing of drywall partition. The accessories are made of galvanized steel and are easy to install. Figures 3.5a to 3.5c provide information on the common accessories available for different finishing purposes.



Stopping angles, a perforated and recessed edge strip, are used when the edge of the plasterboard is not exposed and the fitting of a corner bead is difficult. The stopping angle is fixed with an adhesive or staples, with the finishing coats bonding with the plasterboard and feathering up to the bead nib. In addition, the shadowline stopping angle provides a clean, straight and shadow edge. Shadowline stopping angles are ideal for vertical, horizontal and curved application.

Figure 3.5a Type of Stopping Angles

Types	Details
<p>1. Stopping angle</p> 	
<p>2. Shadowline stopping angle</p> 	



Corner beads are used to achieve strong, straighter, crack-free internal and external corners. The exposed nose of the bead resists impact and forms a base to receive joint compound.

Figure 3.5b Types of Corner Beads

Types	
<p>1. Internal corner bead</p> 	<p>2. External corner bead</p> 

Selection of appropriate fastener and spacing of fastening are crucial to the sturdiness and aesthetics of the final product, and important in meeting the requirement of specific fire-rated construction. Plasterboards are attached to the frames with screws and nails, where there should be adequate edge distance to prevent damage to board edge.

Figure 3.5c Types of Fasteners










Types	Detail
<p>1. Screws</p> 	<ul style="list-style-type: none"> Corrosion-resistant screws
<p>2. Nails</p> 	<ul style="list-style-type: none"> Corrosion-resistant nails

3.6 Tools Selection

Selection of appropriate tools is important for drywall installation. Tools used should be of good quality and properly maintained. They should be checked and cleaned on a daily basis. Tools should be stored in a dry and safe place.

Figure 3.6 Tools Selection

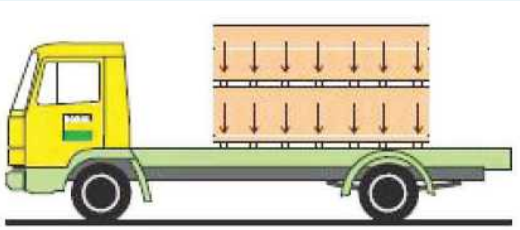

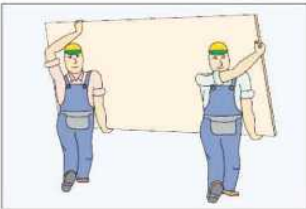
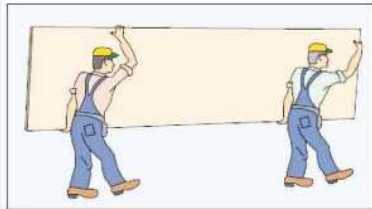
<p>List of tools</p>	<p>Measuring tape</p> 	<p>Carpenter's pencil</p> 	<p>Plumb bob</p> 
<p>Usage</p>	<p>To measure dimension of various materials</p>	<p>To mark the length before cutting</p>	<p>To transfer set out marks from the floor to the ceiling and vice versa</p>
<p>List of tools</p>	<p>Plastering knife</p> 	<p>Plastering hawk</p> 	<p>Spirit level</p> 
<p>Usage</p>	<p>To apply joint compound to plasterboard</p>	<p>To transfer joint compound from its container to plasterboard</p>	<p>To ensure verticality and alignment</p>
<p>List of tools</p>	<p>Aviation snipper</p> 	<p>Hammer</p> 	<p>Drill & Drill Bit</p> 
<p>Usage</p>	<p>To snip tracks, bracings and studs into appropriate sizes</p>	<p>To anchor framing onto ground with nails</p>	<p>To fasten tracks, studs, bracings and boards into position</p>

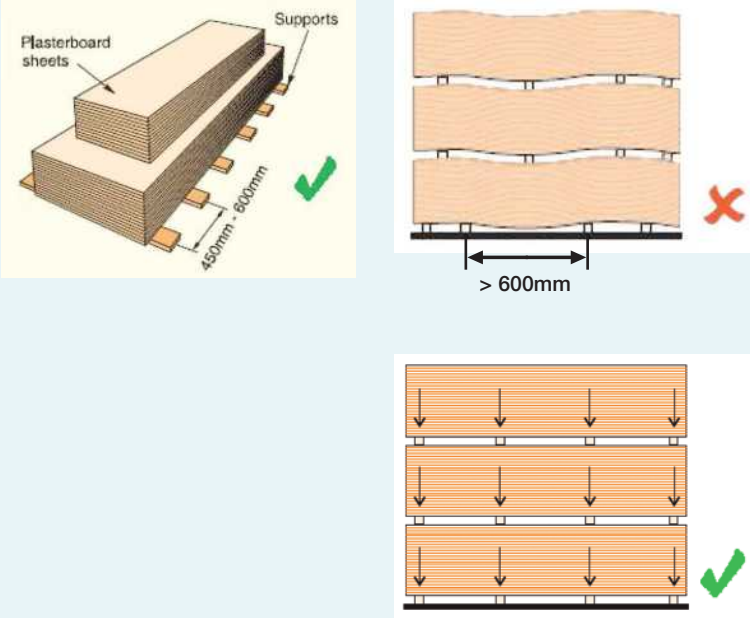
<p>List of tools</p>	<p>Crowbar</p> 	<p>Crimper</p> 	<p>Ink pad</p> 
<p>Usage</p>	<p>To adjust plasterboard into position</p>	<p>To join stud and track together</p>	<p>To mark out setting out position</p>
<p>List of tools</p>	<p>Builder's square</p> 	<p>Flat file</p> 	<p>Auto-level</p> 
<p>Usage</p>	<p>To verify right angle</p>	<p>To file plasterboard and tracks/studs</p>	<p>To make setting out position</p>
<p>List of tools</p>	<p>Ladder or bench</p> 	<p>Mitre Saw</p> 	<p>Fastener</p> 
<p>Usage</p>	<p>To access to top track/runner and top of board</p>	<p>To make accurate crosscuts</p>	<p>To secure boards</p>

4. DELIVERY, HANDLING AND STORAGE

Proper delivery, handling and storage procedures and relevant good practices are important to ensure materials are not damaged prior to installation.

Figure 4.1 Delivery, Handling and Storage

Work Sequence	Good Practices
<p>1. Delivery</p>  	<ul style="list-style-type: none"> • Material delivered as per approved material and sample • To reduce the risk of damage, plasterboards should be delivered to site prior to installation • Plasterboard stacking supports should be spaced at no more than 600mm centres
<p>2. Handling</p>  	<ul style="list-style-type: none"> • Material handling as per approved method statement • During handling and storage, boards should be carried in an 'upright' position with particular care taken to protect the edges

Work Sequence	Good Practices
<p data-bbox="204 504 335 537">3. Storage</p>  <p>The diagrams show three storage scenarios:</p> <ul style="list-style-type: none"> Top-left: A stack of plasterboard sheets supported by small wooden blocks. The distance between supports is labeled as 450mm - 600mm. A green checkmark is next to it. Top-right: A stack of plasterboard sheets supported by widely spaced blocks. A dimension line below the supports indicates a distance of > 600mm. A red X is next to it. Bottom: A stack of plasterboard sheets supported by four evenly spaced blocks. Downward arrows indicate the weight of the sheets above each support. A green checkmark is next to it. 	<ul style="list-style-type: none"> • Material storage as per approved method statement • Plasterboards should be stored in neat, flat stacks off the ground/floor in a dry covered area • If storing outdoors, stack boards on a level, moisture-free platform, and keep fully protected from the weather • Plasterboard stacking supports should be spaced at no more than 600mm centres

5. PREPARATORY WORKS

Proper setting out, dimensional control, sufficient structural support for mechanical and electrical services, openings, together with surface preparation are critical in ensuring drywall sturdiness and quality.

The approved shop drawings dictate the setting out and dimensional control while the approved method statement governs the performance and technical requirement of relevant system, governing standards as well as installation procedures. The approved materials and samples determine the right type of materials to be used.

5.1 Approved Shop Drawing, Method Statement, Material and Sample

5.1.1 Approved shop drawing

An approved shop drawing should ideally include profiles, sizes, connection details, reinforcing anchorage, sizes and types of fasteners, and accessories. Dry-lining details in fire-rated wall, soffit and ceiling assemblies should also be indicated in the approved shop drawings where necessary.

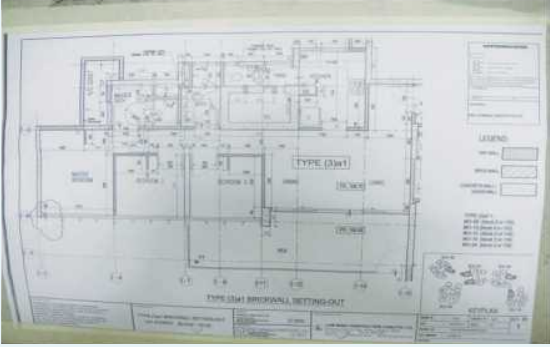
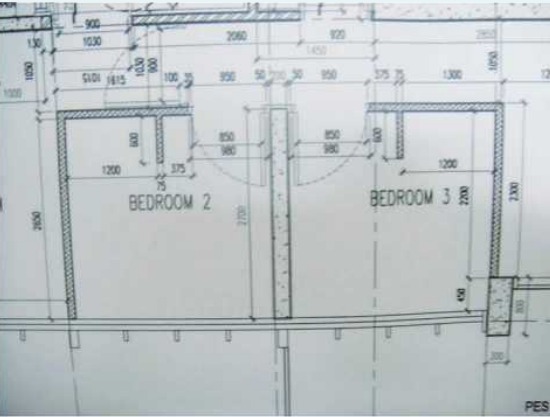


5.1.2 Approved method statement

An approved method statement should ideally comprise recommendation for treatment to the contact surfaces prior to receiving the drywall installation. A recommended good practice for the approved method statement is to highlight the delivery, storage and handling of materials as well as the integration of M&E services installation into the drywall installation process. The approved method statement should consider connection method between different types of materials.

5.1.3 Approved material and sample

All the relevant technical information should be in the approved material submission while relevant approved sample should comprise approved materials and duly endorsed by the architect.



Figure 5.1 Approved Shop Drawings and Method Statement




Working Documents	Good Practices
	<p>a) Setting of reference gridline in accordance to Approved Shop Drawing</p>
	<p>b) Setting out in accordance to Approved Shop Drawing</p>
	<p>c) Verification of material storage and handling in accordance to Approved Method Statement</p>
	<p>d) Approved Sample</p>

5.2 Contact Surface Preparation

Contact surface for drywall installation preparatory works usually refers to end wall or column, soffit of slab and floor slab. Verticality of the end wall or column needs to be checked prior to receiving the starter stud. The evenness of the soffit of slab governs the securing of the top tracks/runners. The floor slab or kerb level and alignment dictates the stability of the bottom tracks/runners. All contact surfaces should be properly cleaned before setting out.

Figure 5.2 Contact Surface Preparation




Work Sequence	Good Practices
	<ul style="list-style-type: none">• Verticality of end wall/column must be checked and rectified prior to installation of the starter stud
	<ul style="list-style-type: none">• Evenness of soffit slab must be checked and rectified prior to the installation of the top tracks/runners

Work Sequence	Good Practices
	<p>For drywall without kerb</p> <ul style="list-style-type: none"> • Floor slab should be level and evenness to be rectified prior to the installation of the bottom track/runner.
	<p>For drywall with kerb</p> <ul style="list-style-type: none"> • Kerb should be provided at wet areas. • Maintain kerb evenness to achieve drywall frame stability.
	<ul style="list-style-type: none"> • Straightness of kerb is important to ensure a good alignment of the partition wall.

5.3 Setting Out Preparation

The setting out preparation can begin once all approved shop drawings, method statement, materials and samples are in order. Gridlines and levels are to be marked out on the end wall or column, soffit slab, and floor slab or kerb before installation works.

Figure 5.3 Setting Out Preparation

Work Sequence	Good Practices
	<ul style="list-style-type: none"> • Dry wall starting line marked out on slab soffit as per approved shop drawings.
	<ul style="list-style-type: none"> • Dry wall starting line marked out on floor slab as per approved shop drawings.
	<ul style="list-style-type: none"> • Dry wall starting line marked out on end wall or column as per approved shop drawings.

Work Sequence



Good Practices

- Door opening marked out on floor slab as per approved shop drawings.



6. INSTALLATION




It is essential to identify location of openings, mechanical and electrical (M&E) services, and other fixtures before installation of drywall. The setting out of the framing system, openings and additional supports are critical contributors toward the functionality of the drywall. Sequence of board installation, proper infill and insulation material installation, and treatment material compatibility are also important to achieving quality work. All site work should be carried out in a safe manner to comply with safety regulations.



6.1 Framing Works

Framing works form the structural component of the drywall. It is also critical towards fulfilling its functionality as a wall. Figure 6.1 highlights the sequence of the framing installation process and the recommended good practices to achieve quality work.

Figure 6.1 Drywall Frame Installation Sequence

Work Sequence	Good Practices
<p>1. Mark out the starting line</p> 	<ul style="list-style-type: none">• To ensure starting line and level as per approved shop drawings.• Starting line should be marked on end wall or column, slab soffit and floor slab.• Opening locations should be marked out.
<p>2. Install top track</p> 	<ul style="list-style-type: none">• To ensure evenness of slab soffit before installing the top track.• Tracks should be fastened to structural elements by using anchor bolt or fastener.• Joints in the tracks shall be butt jointed.




Work Sequence	Good Practices
<p>3. Install bottom track</p> 	<ul style="list-style-type: none"> • Floor is to be levelled before installing the bottom track. • Tracks should be fastened to structural elements by using anchor bolt or fastener. • Joints in the tracks shall be butt jointed.
<p>3.1 Bottom track to incorporate M&E concealed services</p> 	<ul style="list-style-type: none"> • To ensure all M&E concealed services are within the track.
<p>4. Install starter stud</p> 	<ul style="list-style-type: none"> • To ensure verticality of the end wall use a spirit level or laser marker. • Gap to be allocated at top track to allow for deflection of top slab. • Place studs in direct contact with doors frame jambs, abutting partitions, partition corners/edges, and existing construction elements. • To check overall verticality of studs.



Work Sequence	Good Practices
<p>5. Install intermediate studs</p> 	<ul style="list-style-type: none"> • Studs to be installed at interval as per approved shop drawings. • Intermediate studs must face same direction to allow for adjustment when fixing plasterboard. • Do not splice vertical metal stud members. • To check overall verticality of studs.
<p>6. Install bracing</p>  <p>Additional hollow section for bracing and load bearing steel stud</p>	<ul style="list-style-type: none"> • Horizontal bracing for all stud partitions to be as per manufacturer's recommendation. • Provide all braced framing of load bearing steel stud framing as detailed in approved shop drawings.

6.2 Opening

The most common openings on drywall are for doors. Such openings are usually reinforced by the introduction of box stud to stiffen the opening. Figure 6.2 illustrates the sequence of opening stiffening and the relevant good practices to achieve quality work.

Figure 6.2 Framing for Openings



Work Sequence	Good Practices
<p>1. Install starter stud</p> 	<ul style="list-style-type: none"> Fix all starter studs as per approved drawings.
<p>2. Install metal box studs to secure door frame</p> 	<ul style="list-style-type: none"> To secure the door frame, form a metal box stud to fix into back of starter stud. 


Work Sequence	Good Practices
<p data-bbox="172 320 730 376">2.1 Install metal bracing above door frame to secure it</p> 	<ul data-bbox="869 320 1364 380" style="list-style-type: none">• Metal bracing or door head trimmer must be installed for door opening.
<p data-bbox="172 875 550 904">3. Alternative stiffener for door</p> 	<ul data-bbox="869 875 1385 1030" style="list-style-type: none">• Rectangular hollow section or timber with the same width as the stud to be placed and properly secured as per approved shop drawing and method statement.

6.3 Additional Supports for M&E Services and Other Fixtures

Additional supports in the drywall frame are required for fixtures such as Fan Coil Unit (FCU) and electrical switches. Spacing of vertical studs and/or bracing to be adjusted accordingly to accommodate the size and weight of fixtures. Figure 6.3 demonstrates some examples of necessary additional supports and the relevant good practices to achieve quality work.

Figure 6.3 Additional Supports for M&E Services and Other Fixtures

Work Sequence	Good Practices
<p>1. Additional support for M&E services</p> 	<ul style="list-style-type: none"> • Identify location and type of M&E services. • Identify penetration for wiring. • Metal bracing must be provided for the M&E services.
<p>1.1 Install additional bracing for M&E services</p> 	<ul style="list-style-type: none"> • Identify location of M&E services. • Ensure proper planning for wiring to enable provision of opening and bracing for services.

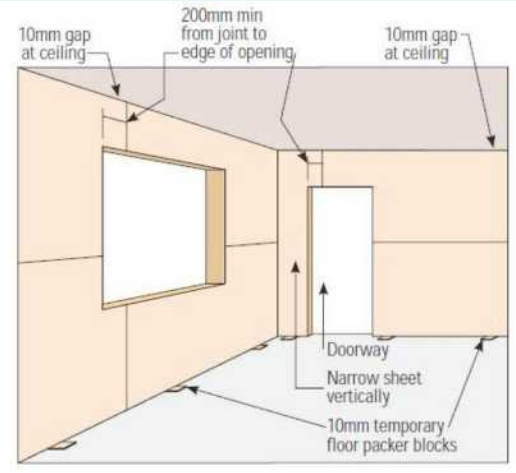

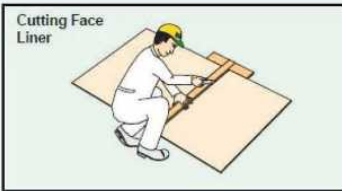
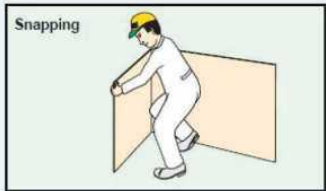
Work Sequence	Good Practices
<p data-bbox="172 322 632 353">1.2 Install additional support for FCU</p> 	<ul data-bbox="863 322 1385 539" style="list-style-type: none">• Identify location of FCU.• Ensure support is sufficient to accommodate FCU.• Metal bracing must be done at FCU to withstand the imposed load.

Any other additional fixtures to be mounted on drywall should be identified early and indicated in all shop drawings as well as method statement for approval. Additional supports should be duly designed and endorsed by the professional engineer.

6.4 Board Installation

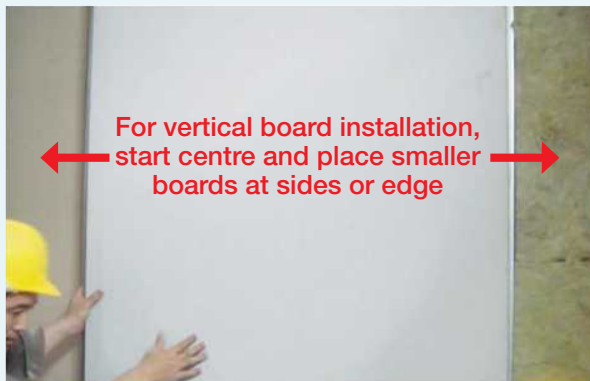
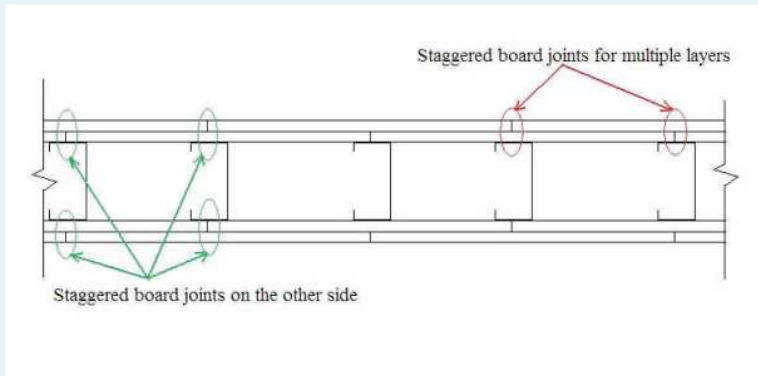
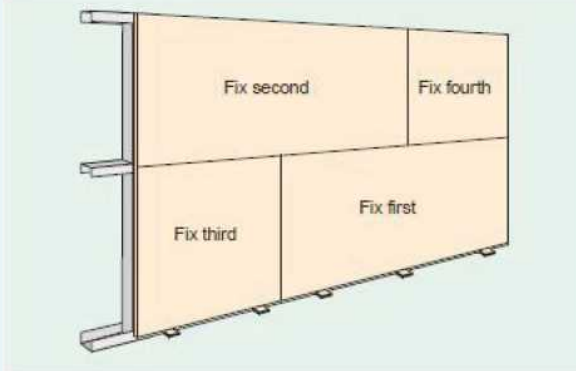
The overall framing installation is heavily dependent on board dimension and type of board layout. Figure 6.4 shows the importance of board dimension affecting framing works and the relevant good practices to achieve quality work.

Figure 6.4 Importance of Board Dimension and Board Layout Affecting Framing Works

Work Sequence	Good Practices
<p>1. Typical board sizes</p> 	<ul style="list-style-type: none"> • Identify and calculate area and layout of board to be installed. • Frame spacing to be in accordance to board dimension and layout.
<p>1.2 Cutting of Boards</p>   	<ul style="list-style-type: none"> • Use proper tools such as T-square and cutting knife to cut boards.


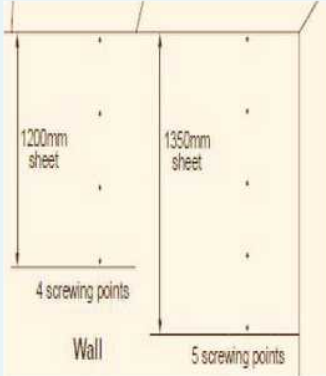


Work Sequence

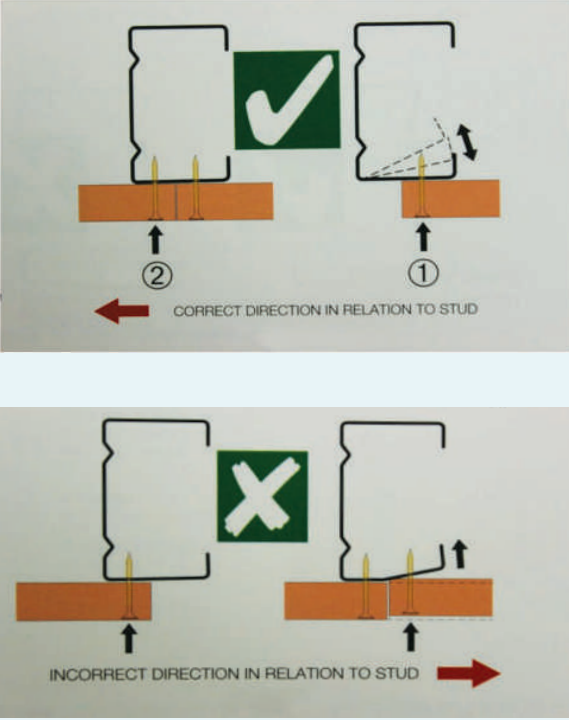
2. Sequence of horizontal board installation



Good Practices

- Ensure horizontal board installation sequence as per method statement.
- Install panels in such a manner that panel joints do not align with edge of opening.
- For multi-layered boards, stagger joints between the layers, as well as on opposite sides of partitions.
- Tightly butt tapered end board edge joints.
- For vertical board installation, start centre and place smaller boards at sides or edge.



Work Sequence	Good Practices
<p>2.1 Securing of board</p>  	<ul style="list-style-type: none"> • All butt joint screws are to be staggered. • Plasterboard screws should be spaced <ol style="list-style-type: none"> i. <300mm for butt joints ii. <200mm for angles joints iii. 10 to 16mm from edges and ends of plasterboard sheets
 <p>Application of drywall screws shall begin from centre outwards.</p>  <p>No fastening of panels to bottom runner/track.</p>	<ul style="list-style-type: none"> • Ensure securing process of the board onto the vertical stud does not cause tilting of flange. Application of drywall screws shall begin from centre outwards. • Install screws from ends and edges of panels, and on centre along abutting end joints; and, on centre within the field of the panel. • Panels shall not fasten directly to the top and bottom runners to allow for top slab deflection movement.

Work Sequence	Good Practices
<p data-bbox="172 320 874 353">3. Sequence of screwing the board onto the vertical stud</p>  <p>The diagram illustrates two scenarios for screwing a board onto a vertical stud. The top scenario, marked with a green checkmark, shows the correct sequence. It consists of two parts: (1) A screw is driven into the board from the bottom edge towards the vertical stud. (2) A second screw is driven into the board from the top edge towards the vertical stud. A red arrow points to the left, labeled 'CORRECT DIRECTION IN RELATION TO STUD'. The bottom scenario, marked with a green X, shows an incorrect sequence. It also consists of two parts: (1) A screw is driven into the board from the bottom edge towards the vertical stud. (2) A second screw is driven into the board from the top edge away from the vertical stud. A red arrow points to the right, labeled 'INCORRECT DIRECTION IN RELATION TO STUD'.</p>	<ul data-bbox="1053 320 1417 672" style="list-style-type: none">• Apply the screws from the leg of top and bottom runners, onto the vertical studs for attachment of the panel.• Proper sequence of board screwing, i.e. correct direction, to the stud to prevent gap between board and stud.

6.5 Infill and Insulation Installation

Proper installation of infill material helps to provide necessary fire resistance and sufficient acoustic insulation. Figure 6.5 shows the proper infill and insulation material installation and the relevant good practices to achieve quality work.



Figure 6.5 Infill and Insulation Material Installation




Work Sequence	Good Practices
<p>1. Typical treatment</p> 	<ul style="list-style-type: none"> Seal all perimeter gap of the wall frame system with relevant material from the approved method statement, material and sample.
<p>2. Placing of infill and insulation material</p> 	<ul style="list-style-type: none"> All infill and insulation material for installation as per approved method statement and material. Ensure all spaces are filled with insulation material. Ensure that all recessed panels, electrical outlets, light switch boxes, etc are encased with fire-barrier seal wrap to seal all gaps and maintain continuity in fire and smoke protection in all fire-rated assemblies.



6.6 Joint Treatment



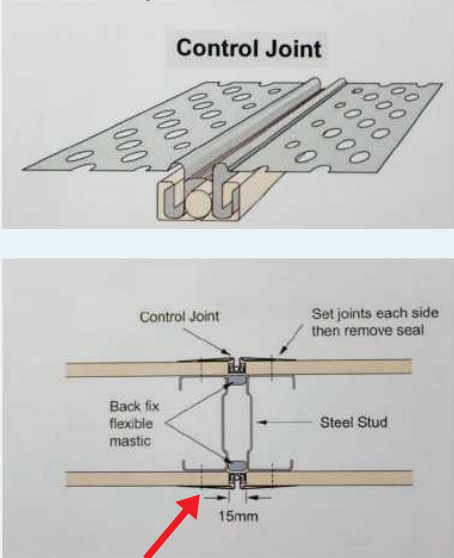
The last procedure of drywall installation is the treatment to various types of joints, edges and corners. Acoustic sealant, corner beads, joint tapes, jointing compound and topping compound are common materials used. Figure 6.6 shows the common types of treatment and the recommended good practices to achieve quality work.


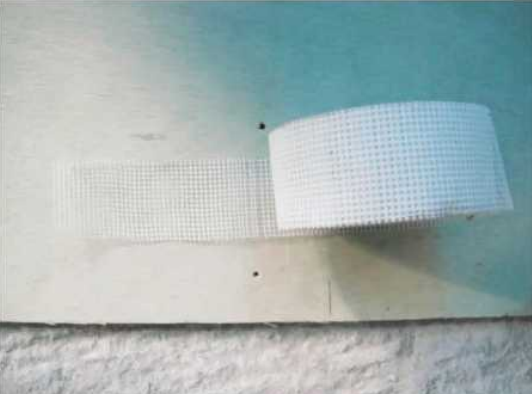

Figure 6.6 Common Types of Joint Treatment

Work Sequence	Good Practices
<p>1. General requirement</p>	<ul style="list-style-type: none"> • Proper enclosure of work areas prior to installation will reduce the impact of environmental changes e.g. fluctuations in temperature, humidity, airflow etc. • Good planning prior to hanging panels can eliminate unnecessary joints.
<p>2. Acoustic sealant</p> <div style="display: flex; flex-direction: column; align-items: center;">   </div>	<ul style="list-style-type: none"> • Proper use of acoustic sealant as stated in approved shop drawing, method statement and material. • Use of acoustic sealant to effectively seal perimeters and openings in wall and ceilings to improve sound transmission rating.

Work Sequence	Good Practices
<p data-bbox="220 320 507 349">3. External corner bead</p> 	<ul data-bbox="847 320 1378 510" style="list-style-type: none"> • Use of external corner bead enables visually straight joint, better corner alignment and neater finishing. • Functions as a protection against edge damage.
<p data-bbox="220 866 568 896">3.1a Fixing of external angle</p> 	<ul data-bbox="847 866 1378 931" style="list-style-type: none"> • Apply a coat of joint compound before placing external angle.
<p data-bbox="220 1408 568 1438">3.1b Fixing of external angle</p> 	<ul data-bbox="847 1408 1289 1438" style="list-style-type: none"> • Place external angle in position.

Work Sequence	Good Practices
<p data-bbox="220 320 568 353">3.1c Fixing of external angle</p> 	<ul data-bbox="847 320 1329 353" style="list-style-type: none"> • Ensure verticality of external angle.
<p data-bbox="212 846 563 880">3.1d Fixing of external angle</p> 	<ul data-bbox="847 846 1401 1003" style="list-style-type: none"> • Ensure the final treatment to the external angle by applying three coats of joint compound at stipulated intervals as specified in the approved method statement.

Work Sequence	Good Practices
<p>3.2a Three coats for all joint treatment</p> 	<ul style="list-style-type: none"> • Provide proper treatment to interfacing and butt joints by applying three coats of joint compound at stipulated intervals as specified in the approved method statement. • This is an example of the application of three coats of joint compound for different surface interfacing treatment.
<p>3.2b Three coats for external angle treatment</p> 	<ul style="list-style-type: none"> • Ensure the final treatment to the external angle by applying three coats of joint compound at stipulated intervals as specified in the approved method statement. • This is an example of the application of three coats of joint compound for external angle treatment.
<p>4. Control joint component</p>  <p>Fasten the control joint at maximum 150mm c/c.</p>	<ul style="list-style-type: none"> • Control joint to be provided <ul style="list-style-type: none"> (i) in long continuous walls at 12 m maximum centres; (ii) for panels of different materials. • Fasten the control joint to the plasterboards at a maximum of 150mm centres.

Work Sequence	Good Practices
<p data-bbox="209 327 560 360">5. Jointing tape / Mesh tape</p>  	<ul data-bbox="847 327 1409 674" style="list-style-type: none"> • Proper use of jointing tape as per approved method statement and material submission. • Jointing tape is used for reinforcement of plasterboard recessed joints, internal angles, surface fractures and repairs to internal walls. • Use of internal corner taping tool for internal corner.
<p data-bbox="209 1294 443 1328">6. Joint compound</p> 	<ul data-bbox="847 1294 1422 1955" style="list-style-type: none"> • Mix proportion to be in accordance to the manufacturer's instruction. • Ensure that compound is used within the stipulated working time as recommended by the supplier, approved method statement and material. • Allow sufficient curing and dry time before sanding and finishing. • Mixing joint compound in clean buckets reduces probability of lumps forming, scratches and harden of material. • Flush and clean compounds from equipment, and brush before the setting action takes place. • Immersion of equipment in water will not prevent hardening of the compound.

6.7 Fixing Items to Drywall

Hanging objects on drywall requires proper fasteners, and knowledge of installation and type of wall material. It is a good practice for the developer to work with the drywall supplier and builder to develop and issue an instruction manual to new homeowners on how to fix items on the drywall.

The correct fixing method depends on the weight of the fixtures and the type of drywall board used.

Wall anchorage

Wall anchorages can be generally classified into 2 main categories, namely:

Light to medium duty anchor (approximately up to 12 kg per point load); and

Heavy duty anchor (approximately 20 kg per point load).

The types and installation methods of some of the common anchors are illustrated in Appendix B.

Light weight fixtures

Light weight fixtures such as pictures frame, small mirrors, light shelves, lamps, tools, sports equipment, etc. can be fixed with simple screw or expandable plastic screw anchor directly on the board wall.

Medium weight fixtures

For medium weight objects such as big mirror, large picture frame or medium size shelve, etc. of up to 12 kg, stronger types of anchorage fitting may be required. It is important the weight of the fixture should not exceed the weight rating of the anchorage. The weight limits of the anchorage can be found on the packaging.

Heavy weight fixtures

For heavy items such as television, wall cabinet and other heavy wall attachments, it is recommended that such fixing be installed by trained skilled personnel. For such heavy fixtures, the anchors are usually fastened onto the studs frame. The number and types of anchors used will be determined by the weight and usage of the fixtures.

It is advisable to refer to the drywall manufacturer's recommendation for the types of anchors to be used for fixing/hanging items onto the drywall.




7. PROTECTION

Protection to construction works is always essential towards ensuring the quality of finishing works as well as limiting number of defects. Drywall protection to construction works can be in-process and after completion. Window opening next to drywall should be covered before installation of drywall to protect the in-process and completed work from the elements.

Proper handing over record for each individual trade will help to reduce disputes between subcontractors. It is recommended to have records of work condition handed over including personnel entering and exiting the area of work. Control of access is critical to the protection of drywall. Control of access to the individual area or room will help reduce human and work activities that may damage the finished product. It is recommended to limit access to “Authorized Personnel Only”.

Protection is also important during polishing/sanding of floors and such protection must be in accordance to approved method statement as different types of protection cater for different types of floor finishing work.

Figure 7.1 Protection

Working Documents / Sequence	Good Practices
	<p>a) External walls to be constructed before installation of drywall.</p>
	<p>b) Cleared inspection form can be a form of record for proper handing over.</p>
	<p>c) Assigning designated person for access to units is a form of control of access.</p>

8. WET AREAS APPLICATION

Usage of drywall at wet areas is not new. It has been widely used in Europe and Australia for many years. However, the use of board system for wet areas is only a recent trend locally. Its performance is still being monitored and evaluated for its effectiveness.

This section features properties of board system in wet areas application's and some recommended good practices.

8.1 Board System

Wet areas board system should incorporate moisture resistant features. The boards should be resistant to mould growth and are coated to allow for better bonding with tile adhesives (Figure 8.1a) and waterproofing membranes (Figure 8.1b). It also has a homogeneous structure that impedes de-lamination under moist condition.

Figure 8.1a Installation of Wall Finish on Board Partition by Using Adhesive.

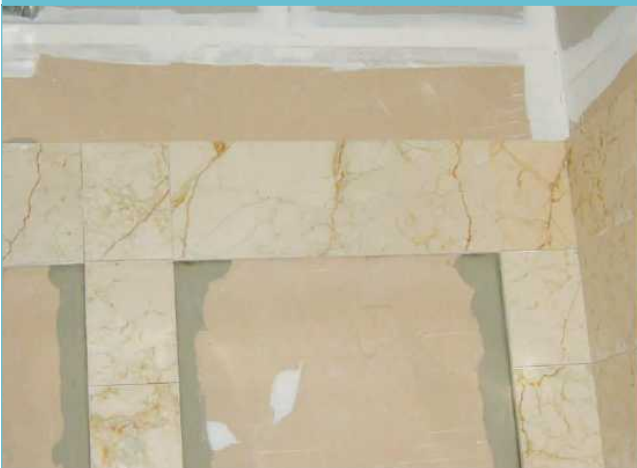


Figure 8.1b Drywall Partition with Waterproofing Membrane



Table 8.2 Properties of Board for Wet Area Application

Properties	Description
1. Moisture Resistance	<ul style="list-style-type: none"> • Long Term Moisture Susceptibility Test to Shower Unit. • Not suitable for use in areas subjected to standing water such as saunas.
2. Mould Resistance	<ul style="list-style-type: none"> • Mould Resistance Test to ASTM standard.
3. Finishing Flexibility	<ul style="list-style-type: none"> • Features a smooth paintable surface that can be finished with tiling. • Independent Tile Adhesion Pull-out Tension Test.

8.2 Recommended Good Practices

To achieve maximum effectiveness in drywall construction in wet areas, the suppliers' manual must be strictly followed. However, if detailing needs to be customised to suit individual project the customised detailing should be clarified with the specialist board system supplier. It is a good practice to carry out compatibility test prior to use. Additionally, it is also a good practice to construct concrete kerb around the wet areas and sit the stud frame on the concrete kerb (Figure 8.2).

Figure 8.2 Stud Erection on a Concrete Kerb in Wet Areas.



Recommended detailing for dry/wet area interfacing is illustrated in Figure 8.3 and recommended detailing for drywall used in wet areas is shown in Figure 8.4.

Figure 8.3 Detailing for Dry/Wet Area Interfacing.

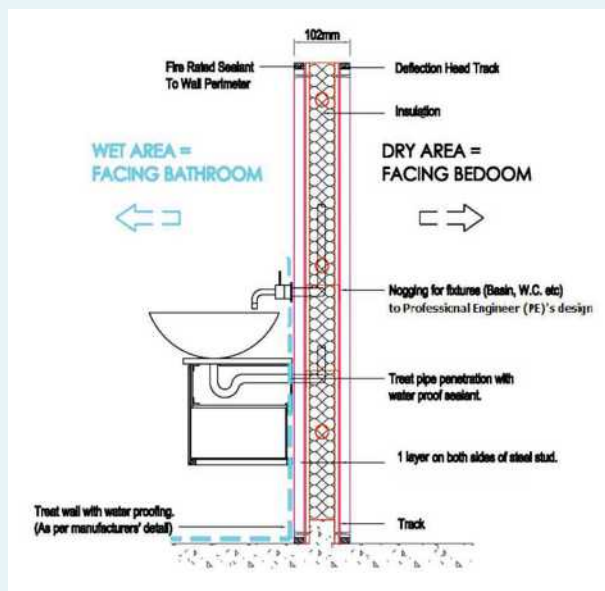
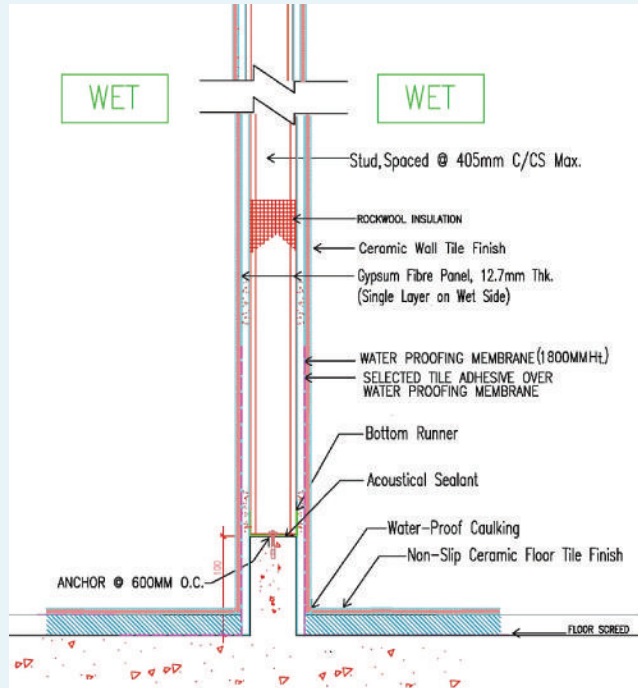


Figure 8.4 Detailing for Wet Area Application.



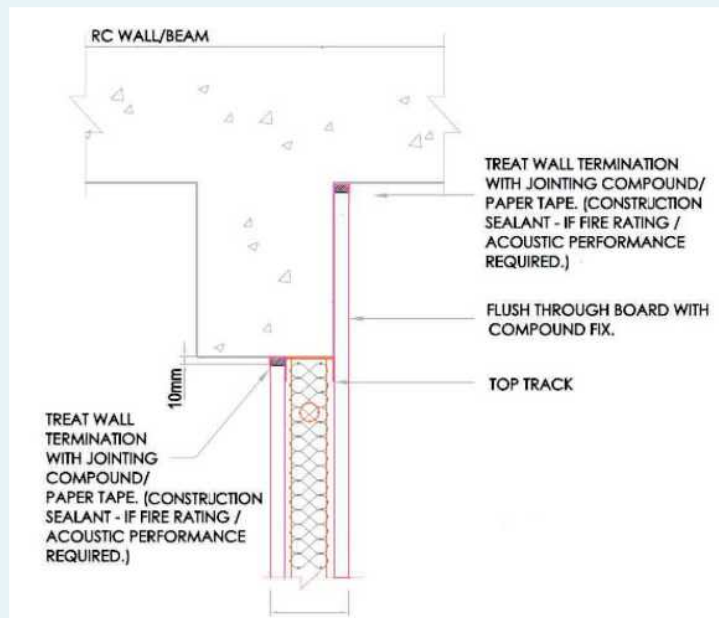
9. RECOMMENDED DETAILING

Good construction detailing often resolves problems arising during construction and defect liability period. Such detailing is usually recommended by manufacturer basing on their experience faced from past project. Table 9.1 recommend some good detailing towards achieving quality.

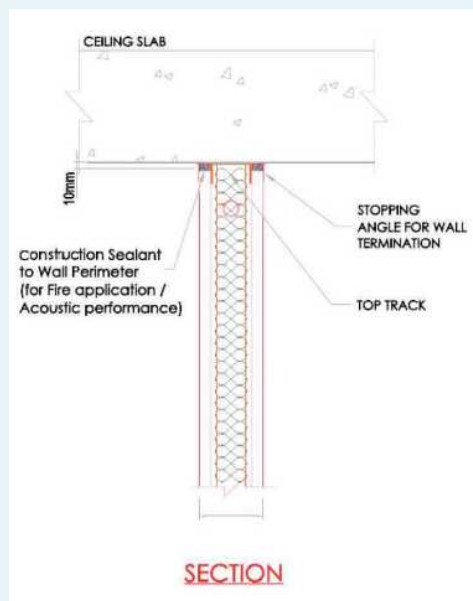
Table 9.1 Recommended Good Detailing

Recommended Good Detailing

1. Drywall and RC wall/beam joint detail

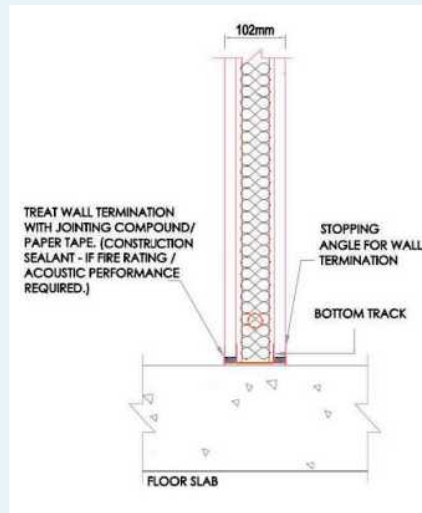


2. Drywall and ceiling slab joint detail

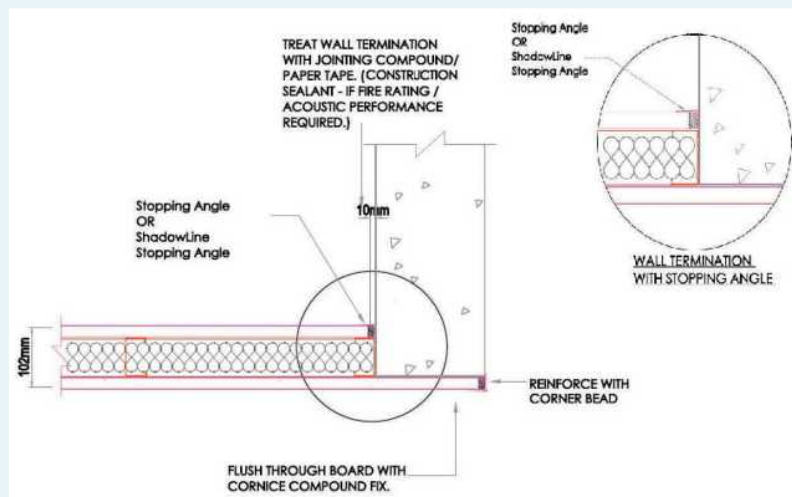


Recommended Good Detailing

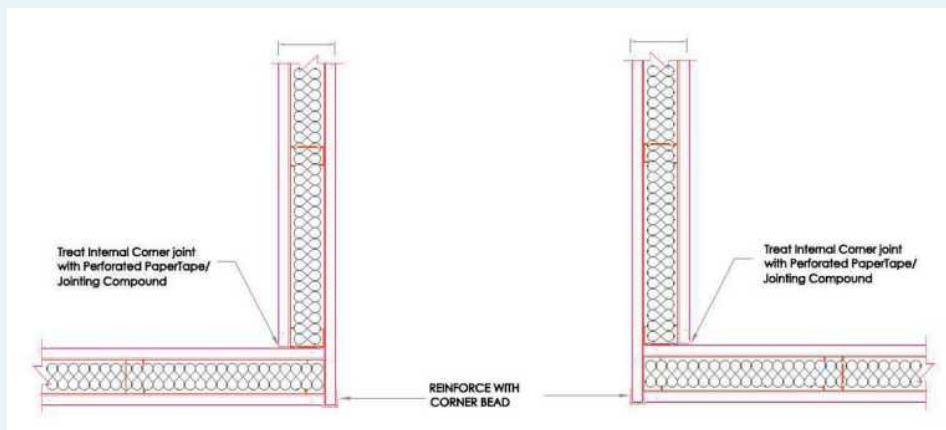
3. Drywall and floor slab joint detail



4. Drywall and wall joint detail

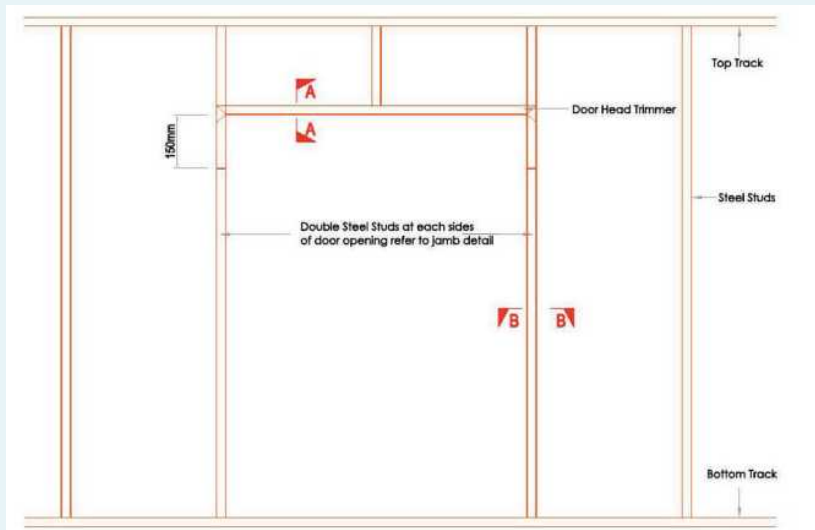


5. Drywall intersection joint detail

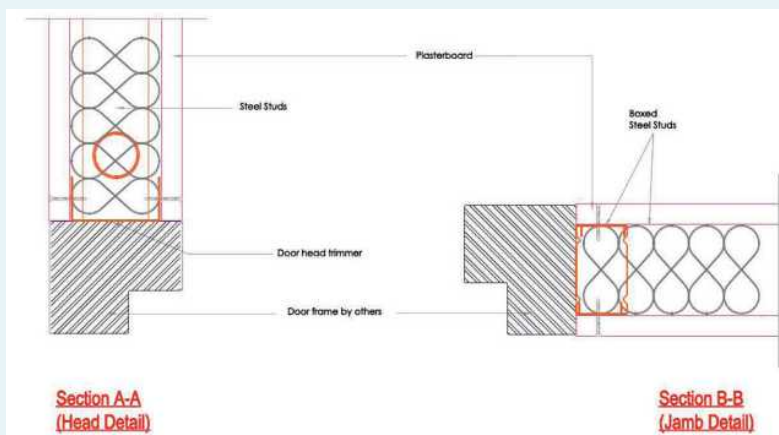


Recommended Good Detailing

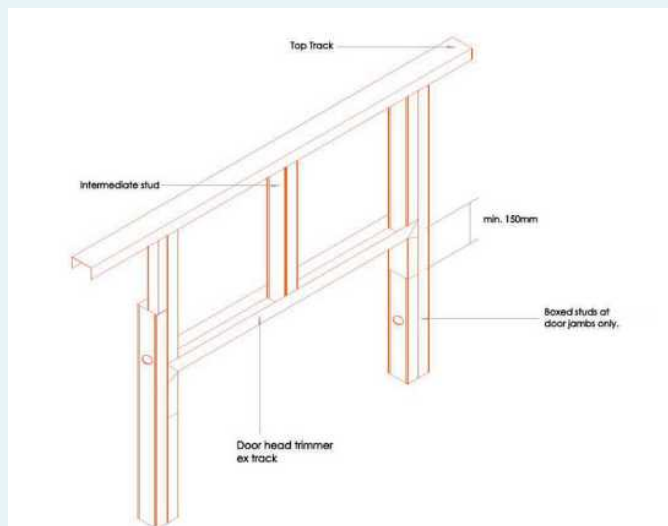
6. Door opening elevation



6.1 Door opening section

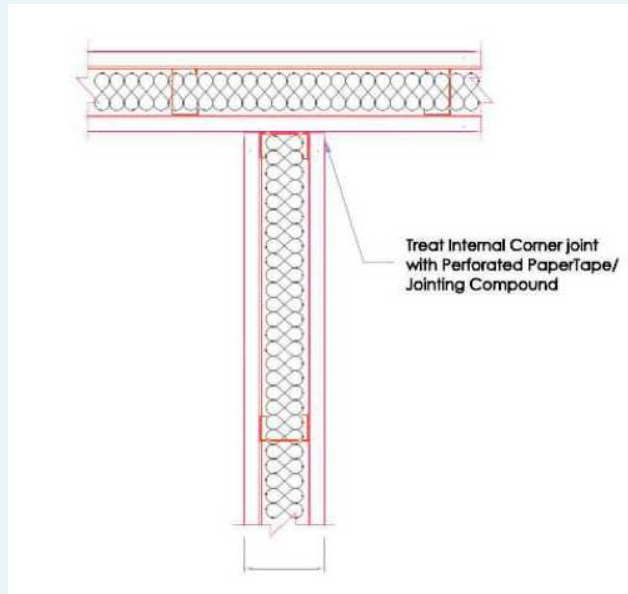


7. Door head trimmer detail

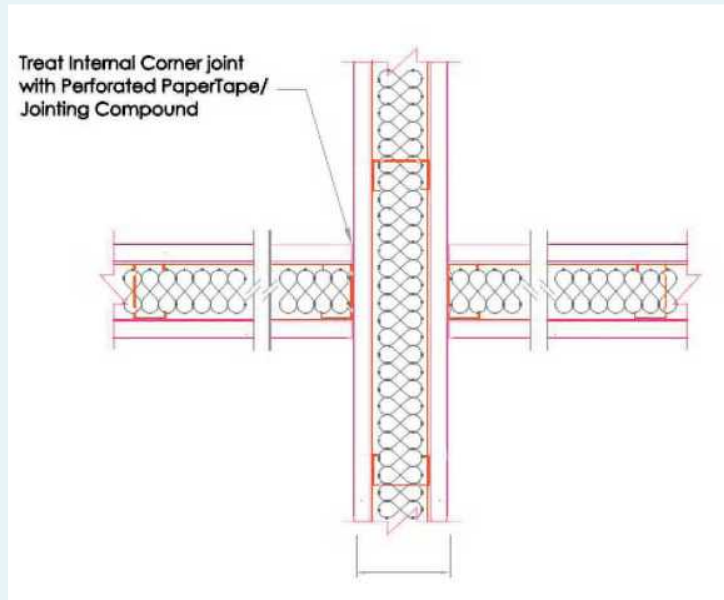


Recommended Good Detailing

8. Drywall intersection detail







9. Drywall intersection detail





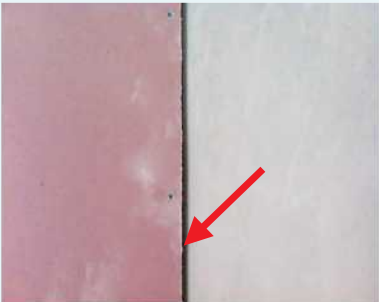



10. COMMON DEFECTS AND REMEDIES

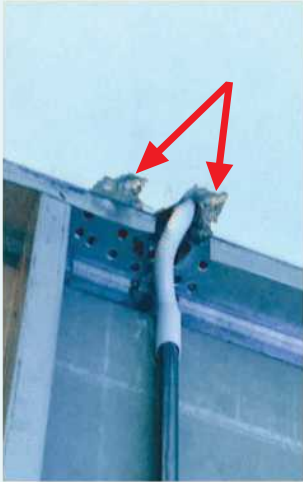
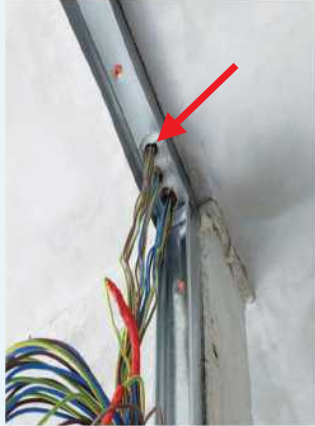

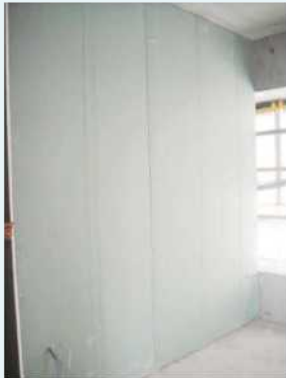


Designers, contractors and site supervisory staff should understand the common defects and their related causes to prevent them. It is also essential to use some recommended details to better manage the defects and implement necessary remedial actions. Figure 10.1 shows the common defects, possible causes and their remedial actions.

Figure 10.1 Common Defects, Possible Causes and Recommendations

Common Defects / Bad Practices	Possible Causes	Recommendations
<p>10.1.1 Cut pieces</p> 	<ul style="list-style-type: none"> • Insufficient planning of layout • Late delivery of material 	<ul style="list-style-type: none"> • Plasterboard must be cut according to shop drawing • Allow tolerable gap for flexible sealant 
<p>10.1.2 Stud cutting for switch casing installation</p> 	<ul style="list-style-type: none"> • Insufficient planning • Last minute changes • Insufficient training 	<ul style="list-style-type: none"> • Stud placement must be according to shop drawing (inclusive of M&E services layout) • Stud realigned to avoid switch casing or alternatively, additional stud is required 

Common Defects / Bad Practices	Possible Causes	Recommendations
<p>10.1.3 Poor cutting of plasterboard</p> 	<ul style="list-style-type: none"> No provision of right tools Insufficient training 	<ul style="list-style-type: none"> Panel must be cut according to shop drawing Over cut / slanting / Rough cut is not allowed 
<p>10.1.4 Missing timber stiffener</p> 	<ul style="list-style-type: none"> Insufficient planning Insufficient training 	<ul style="list-style-type: none"> Timber (1x2 or 2x2) as stiffener Alternatively, it has to be double studs to form boxed at door jamb 
<p>10.1.5 Gaps between different materials</p> <ul style="list-style-type: none"> No gap allowed Gap was filled by mortar filling instead of flexible sealant. 	<ul style="list-style-type: none"> Insufficient planning Insufficient training Lack of supervision 	<ul style="list-style-type: none"> All gaps are to be sealed using Fire Rated Sealant or relevant sealant 



Common Defects / Bad Practices	Possible Causes	Recommendations
<p>10.1.6 Gaps between plasterboard</p> <ul style="list-style-type: none"> Joints not tightly butt tapered end board edge joints 	<ul style="list-style-type: none"> Insufficient training Poor workmanship 	<ul style="list-style-type: none"> Joints must be tightly butt tapered end board edge joints 
<p>10.1.7 Studs not fastened to bottom track</p> 	<ul style="list-style-type: none"> Lack of supervision Insufficient training Poor workmanship 	<ul style="list-style-type: none"> All Studs and Bracing must be riveted/ screwed  



Common Defects / Bad Practices	Possible Causes	Recommendations
<p>10.1.8 M&E Services not within drywall setting out</p> 	<ul style="list-style-type: none"> • Insufficient planning • Insufficient training • Poor workmanship 	<ul style="list-style-type: none"> • All Electrical Services must be within drywall setting out 
<p>10.1.9 Small cut pieces installed and torn board</p> 	<ul style="list-style-type: none"> • Insufficient planning • Insufficient training • Poor workmanship and supervision 	<ul style="list-style-type: none"> • Full piece & proper joint. 
<p>10.1.10 Bottom track cut to accommodate M&E services</p> 	<ul style="list-style-type: none"> • Insufficient planning • Insufficient training • Poor workmanship and supervision 	<ul style="list-style-type: none"> • Services Holes was created without cutting track 

Common Defects / Bad Practices	Possible Causes	Recommendations
<p>10.1.11 Cracks</p> 	<ul style="list-style-type: none"> • Poor detailing • Insufficient supervision • Insufficient training • Poor workmanship 	<ul style="list-style-type: none"> • Proper detailing • Proper supervision • Proper training

Figure 10.2 illustrates some examples of good finishing

Figure 10.2 Examples of Good Finishing

<p>10.2.1 Wall jointing</p> 	<ul style="list-style-type: none"> • No gap between door frame/ architrave
<p>10.2.2a Wall alignment and evenness</p> 	<ul style="list-style-type: none"> • Square-ness less than 4mm over 300mm

<p>10.2.2b Wall alignment and evenness</p> 	<ul style="list-style-type: none">• Less than 3mm over 1.2m length
<p>10.2.3 M&E and wall alignment</p> 	<ul style="list-style-type: none">• No uneven gap between FCU and Drywall
<p>10.2.4 Wall jointing, crack and damages</p> 	<ul style="list-style-type: none">• Drywall should be visually straight• No chips , roughness and scratches allowed
<p>10.2.5 M&E jointing</p> 	<ul style="list-style-type: none">• Electrical switches should be in the same alignment and level.• No gap is allowed between switches and drywall

Wall Comparison By Functional Requirements

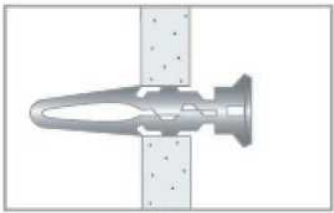


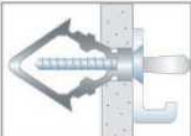
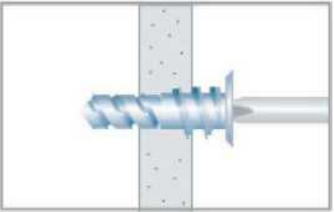
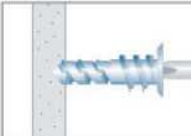
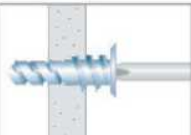
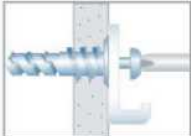
APPENDIX A

Requirements	Hollow-core Panel (90mm thick)	Autoclaved Lightweight Concrete Panel (100mm thick)	Precast Concrete Panel (100mm thick)
Weight	~240 kg/ m	~195 kg/ m	~420 kg/ m
Productivity	15 – 25m ² /man-day	15– 20m ² /man-day	16m ² /man-day
Non-Combustibility BS 476 : Pt 4	Pass	Pass	Pass
Fire Rating BS 476 : Pt 20 & Pt 22	120 mins	194 mins	120 mins
Sound Insulation	~STC42	~ STC36 - 40	~ STC42
Usage in Wet Areas	Yes	Yes	Yes
On-Site Installation of Concealed Wiring, Ducting & Pipework	After installation of wall, services can be concealed within the core of the wall and surface can also be chased.	At joint locations or edges of panel, where there is no reinforcement.	During installation of wall, services can be run through wall cell. After installation of wall, wall surface can be chased. Void within wall to be filled with packing material.
Surface Appearance	Smooth with skim coat	Smooth with skim coat	Smooth with skim coat
Applied Finishes: Tiling	Yes	Yes	Yes
Joint Treatment	Cementitious joint compound is applied between abutting panels.	Cementitious low strength non-shrink material.	Cementitious joint compound is applied between abutting panels.
Fastener Types	<ul style="list-style-type: none"> • Cavity Anchors • 'U' & 'L' Metal Fastener 	<ul style="list-style-type: none"> • Plastic Plugs • Lightweight Concrete Anchors 	<ul style="list-style-type: none"> • Cavity Anchors
Flexibility of Relocation	Can be removed and replaced with relative ease and minimal mess	Can be removed and replaced with relative ease and minimal mess	Can be removed and replaced with relative ease and minimal mess

This table provides only indicative values. Please refer to respective suppliers for individual product's specification

Sample of Fixing Items

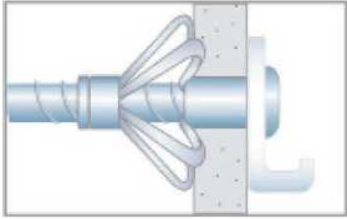
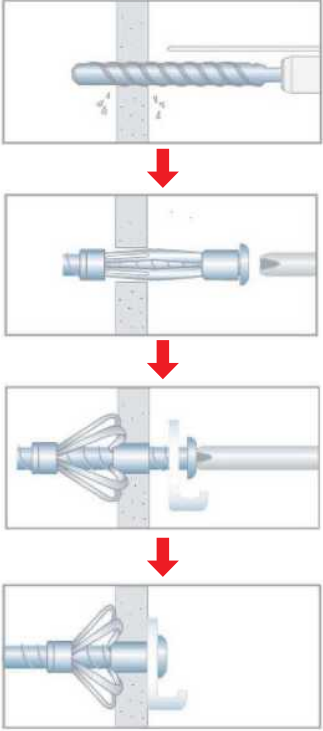
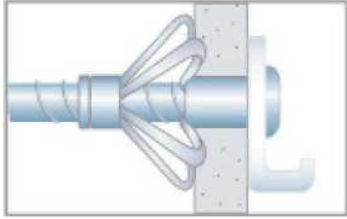
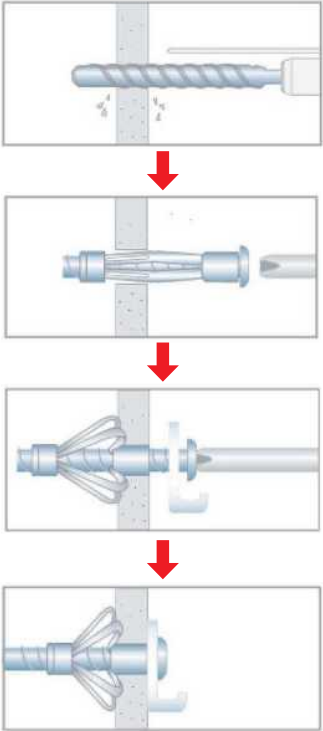
APPENDIX B

	Types of Anchors	Installation Method
<p>Light Duty</p>	 <p>Plugs</p>	 <p>Mark out and Drill.</p> <p>↓</p>  <p>Compress 'wings' and push plugs into hole. Lightly tap plug flush with surface</p> <p>↓</p>  <p>Position fixture, screw and tighten until secure.</p>
	 <p>Self-Drill Fixing</p>	 <p>Push fixing with a screwdriver into board to create a pilot hole.</p> <p>↓</p>  <p>Screw in fixing until flush with base material.</p> <p>↓</p>  <p>Place fixture in position, insert screw and tighten until secure. Only use the screws which are provided.</p>

Note: It is advised that all fixing should be in accordance to manufacturer's recommendation.

Sample of Fixing Items

APPENDIX B

	Types of Anchors	Installation Method
<p>Medium Duty</p>	 <p>Medium Duty</p>	
<p>Heavy Duty (approx. 20kg/ point load)</p>	 <p>Heavy Duty (For heavy duty anchorage, it is recommended to anchor onto the drywall framework)</p>	

Note: It is advised that all fixing should be in accordance to manufacturer's recommendation.

Sample of Inspection & Test Plan

APPENDIX C

Project:

Scope of work: Dry Wall

S/No	Activity	People-In-Charge	Inspection Method	Requirement Reference	Frequency	Acceptance Criteria	Stages	Records
1	Submission (Shop Drawing / Method Statement)							
1.1	Shop Drawings (include M&E services)	BR / ADOS	Review	Section 2 Section 3	Each type of Dry Wall	Conform to Specification & Construction Drawings	Prior to Start Work	Approved Submission
1.2	Method Statement	BR / ADOS	Review	Section 2 Section 3	Each type of Dry Wall	Conform to Specification	Prior to Start Work	Approved Submission
1.3	PE Calculation (where applicable)	BR / QPDW / ADOS	Review	Section 2 Section 3	Specific type of Dry Wall	Conform to Regulation & Specification	Prior to Start Work	Approved Submission
1.4	Material Submission <ul style="list-style-type: none"> • Runner/Studs/Tracks • Boards • Compound • Accessories • Test reports 	BR / ADOS	Review	Section 3	Each type of Dry Wall	Conform to Specification	Prior to Start Work	Approved Submission
1.5	Sample Submission <ul style="list-style-type: none"> • Runner/Studs/Tracks • Boards • Compound • Accessories 	BR / ADOS	Review	Section 3	Each type of Dry Wall	Conform to Specification	Prior to Start Work	Approved Submission
Prepared By:			Verified By:					
Date:			Date:					
Legend			BR – Builder Rep.		QPDW – Qualified Person Dry Wall		ADOS – Architect / Designer / Owner / Supervisory Personnel	

The graphic shown here serves as a guide only.

Sample of Inspection & Test Plan

APPENDIX C

Project:

Scope of work: Dry Wall

S/No	Activity	People-In-Charge	Inspection Method	Requirement Reference	Frequency	Acceptance Criteria	Stages	Records
2	Incoming Material Inspection							
2.1	Types of Material Delivered <ul style="list-style-type: none"> • Runner / Studs / Tracks • Boards • Compound • Accessories 	BR / ADOS	Visual / Specifications	Section 4	Each Delivery	Conform to Specification	Prior to Start Work	Delivery Document
2.2	Storage of Material <ul style="list-style-type: none"> • Runner / Studs / Tracks • Boards • Compound • Accessories 	BR / ADOS	Visual / Specifications	Section 4	Each Delivery	Conform to Specification	Prior to Start Work	Delivery Document
2.3	Selection of Material for Testing <ul style="list-style-type: none"> • Runner / Studs / Tracks • Boards • Accessories 	BR / ADOS	Visual / Testing	Section 3	Random Selection	Conform to Specification	Prior to Start Work	Delivery Document
Prepared By:			Verified By:		Approved By			
Date:			Date:		Date:			
Legend		BR – Builder Rep.	QPDW – Qualified Person Dry Wall	ADOS – Architect / Designer / Owner / Supervisory Personnel				

The graphic shown here serves as a guide only.

Page 2

Sample of Inspection & Test Plan

APPENDIX C

Project:

Scope of work: Dry Wall

S/No	Activity	People-In-Charge	Inspection Method	Requirement Reference	Frequency	Acceptance Criteria	Stages	Records
3	Preparation							
3.1	Method of Installation	BR / ADOS	Visual / Specifications	Section 2 Section 3	Each Location	Conform to Specification	Prior to Start Work	Approved Submission
3.2	Mock Up Unit	BR / ADOS	Visual / Measurement	Section 6	Each Location	Conform to Approved Drawings & Specification	Prior to Start Work	Approved Submission
4	Installation							
4.1	Method of Installation	BR / ADOS	Visual / Measurement	Section 6	Each Location	Conform to Approved Drawings & Specification	Before Installation	Checklist
4.2	Setting Out Check	BR / ADOS	Visual / Measurement	Section 6	Each Location	Conform to Approved Drawings & Specification	Before Installation	Checklist
4.3	Framing Works	BR / ADOS	Visual / Measurement	Section 6	Each Location	Conform to Approved Drawings & Specification	Before Closing Any Board	Checklist
Prepared By:								
Date:								
Legend								
BR – Builder Rep.			QPDW – Qualified Person Dry Wall			ADOS – Architect /Designer / Owner / Supervisory Personnel		
Approved By								
Date:								

The graphic shown here serves as a guide only.

Sample of Inspection & Test Plan

APPENDIX C

Project:

Scope of work: Dry Wall

S/No	Activity	People-In-Charge	Inspection Method	Requirement Reference	Frequency	Acceptance Criteria	Stages	Records
4	Installation (Continued)							
4.4	Openings	BR / ADOS	Visual / Measurement	Section 6	Every Opening	Conform to Approved Drawings & Specification	Before Closing Any Board	Checklist
4,5	Lateral Bracing	BR / ADOS	Visual / Measurement	Section 6	Each type of Dry Wall	Conform to Approved Drawings & Specification	Before Closing Any Board	Checklist
4.6	Additional Support for M&E Services	BR / ADOS	Visual / Measurement	Section 6	Each M&E Service	Conform to Approved Drawings & Specification	Before Closing Any Board	Checklist
4.7	Vertical and Alignment Check	BR / ADOS	Visual / Measurement	Section 6	Each Location	Conform to CONQUAS Standards	Before Closing Any Board	Checklist
4.8	M&E Services Installation	BR / ADOS	Visual / Measurement	Section 6	Each M&E Service	Conform to Approved Drawings & Specification	Before Closing Any Board	Checklist
Prepared By:			Verified By:		Approved By			
Date:			Date:		Date:			
Legend		BR – Builder Rep.	QPDW – Qualified Person Dry Wall	ADOS – Architect / Designer / Owner / Supervisory Personnel				

The graphic shown here serves as a guide only.

Sample of Inspection & Test Plan

Project:

Scope of work: Dry Wall

S/No	Activity	People-In-Charge	Inspection Method	Requirement Reference	Frequency	Acceptance Criteria	Stages	Records
4	Installation (Continued)							
4.9	1 st Closing of Board Installation	BR / ADOS	Visual / Measurement	Section 6	Each Unit	Conform to Approved Material & Sample	Before Closing Any Board	Checklist
4.10	Infill / Insulation Material Installation	BR / ADOS	Visual / Measurement	Section 6	Each Unit	Conform to Approved Material & Sample	Before Closing Any Board	Checklist
4.11	Inspection by PE (where applicable)	BR / QPDW / ADOS	Visual / Measurement	Section 6	Specific type of Dry Wall	Conform to Approved Drawings & Specification	Before Closing Any Board	Checklist
4.11	Final Closing of Board Installation	BR / ADOS	Visual / Measurement	Section 6	Each Unit	Conform to Approved Material & Sample	Before Closing Any Board	Checklist
4.12	Joint, Corner and Interfacing Treatment (include Damage repair)	BR / ADOS	Visual	Section 6	Each Location	Conform to CONQUAS Standards	After Closing Any Board	Checklist
Prepared By:		Verified By:		Approved By				
Date:		Date:						
Legend		BR – Builder Rep.		QPDW – Qualified Person Dry Wall		ADOS – Architect / Designer / Owner / Supervisory Personnel		

Sample of Inspection & Test Plan

APPENDIX C

Project:

Scope of work: Dry Wall

S/No	Activity	People-In-Charge	Inspection Method	Requirement Reference	Frequency	Acceptance Criteria	Stages	Records
4	Installation (Continued)							
4.13	Performance Test	BR / ADOS	Visual/ Specification/ Measurement	Section 6	Each type of Dry Wall	Conform to Specification	After Final Closing of Board	Checklist
4.14	Final Check and Repair before receiving Painting works	BR / ADOS	Visual	Section 10	Each type of Dry Wall	Conform to Specification & CONQUAS Standards	After On Site Testing	Checklist
4.15	Protection	BR / ADOS	Visual	Section 7	Each type of Dry Wall	Conform to Specification	After Final Repair Done	Checklist
Prepared By:			Verified By:		Approved By			
Date:			Date:		Date:			
Legend		BR – Builder Rep.	QPDW – Qualified Person Dry Wall	ADOS – Architect / Designer / Owner / Supervisory Personnel				

Request for inspection Form

APPENDIX D

Project Title: AB Condominium		Main Contractor: 123 Contractor Pte Ltd			
Work Trade: Dry Partition Wall Installation		Dry Wall Applicator: XYZ Strongwall Pte Ltd			
Location of Inspection: Block: 82		Unit No: 55-43			
Signature, Date & Time of Inspection form submitted: <i>By Builder Rep.</i>		Signature, Date & Time of Inspection form received: <i>By RE/RTO</i>			
		ITP Reference No: 4 (Installation)			
		Drawing No: Arch/ABC/DWSD/01A			
<input type="checkbox"/> 1st Inspection		<input type="checkbox"/> 2nd Inspection			
<input type="checkbox"/> 3rd Inspection					
Description of Activities	By Builder Rep.		Comments by RE/RTO	By RE/RTO	
	Signature	Date		Signature	Date
PRE-ERECTION CHECK <ul style="list-style-type: none"> • Drawing Used • Materials Used • Accessories Used 			<input type="checkbox"/>		
SETTING OUT CHECK <ul style="list-style-type: none"> • Gridline/Ref. Line • Setting out line • Check Level • Opening position 			<input type="checkbox"/>		
INSTALLATION CHECK <ul style="list-style-type: none"> • Framing • Studs & Studs' Verticality • Lateral Bracing 			<input type="checkbox"/>		
Close 1st side of Board <ul style="list-style-type: none"> • M&E Services installation • Additional M&E Services Support 			<input type="checkbox"/>		
FINAL CLOSING OF BOARD <ul style="list-style-type: none"> • Infill / Insulation 			<input type="checkbox"/>		
TREATMENT Joint, Corner and Interfacing			<input type="checkbox"/>		
PERFORMANCE TESTS			<input type="checkbox"/>		
FINAL CHECK Before Painting commence			<input type="checkbox"/>		
<input type="checkbox"/> You may proceed with the next stage of work <input type="checkbox"/> You are not to proceed with next stage of work <input type="checkbox"/> Others (Please Specified): _____	Endorsement by RE/RTO:		Acknowledgement By Builder:		
	<i>Date & Time of Endorsement</i>		<i>Date & Time of Acknowledgement</i>		
	<i>Inspector Signature</i>		<i>Builder Rep Signature</i>		

REFERENCES

- i. SS 492:2001
Specification for Performance Requirements for Strength and Robustness (including methods of test) for Partition Walls
- ii. BS 476
Fire Tests on Building Materials and Structures – Part 4: Non-combustibility Test for Materials
- iii. BS 476 - 22:1987
Methods of Determination of the Fire Resistance of Non-loadbearing elements of construction
- iv. BS 1230 Part 1 (Replaced by BS EN 520:2004)
Certificate of Conformity (Determination of Surface Water Resistance for Plasterboard)
- v. BS 5234 - 2:1992
Structural Test for Partitions including matching linings
- vi. ASTM E90 - 97
Measurement of Airborne Sound Transmission Loss of Building Partitions & Elements
- vii. ASTM D3273 - 00(2005)
Standard Test Method for Resistance to Growth of Mold on the Surface of Interior Coatings in an Environmental Chamber
- viii. AS 1170.1 & 1170.2
Drywall Steel Structure Dead Load, Live Load & Load Combination
- ix. BCA - CITI
Singapore Trade Test Syllabus for Ceilings & Partition
- x. BCA
The Buildable Wall Systems